

CONTEMPORARY STORAGE SYSTEM INSTALLATION INSTRUCTIONS

You would have already decided on the number of bays you require therefore you will have the correct number of stanchions, shelves, hanger bars etc. If you have ordered glass shelves, the stanchions must be installed to either 600mm or 900mm centres. The stanchions for drawer units must be at 600mm centres. The stanchions for MFC shelves and hanger bars can be set at any centre size 1200mm & under to fit your requirements. The MFC shelf and hanger bar can then be cut down to fit.

IMPORTANT: Familiarise and identify the various parts using the illustrations in these assembly instructions.

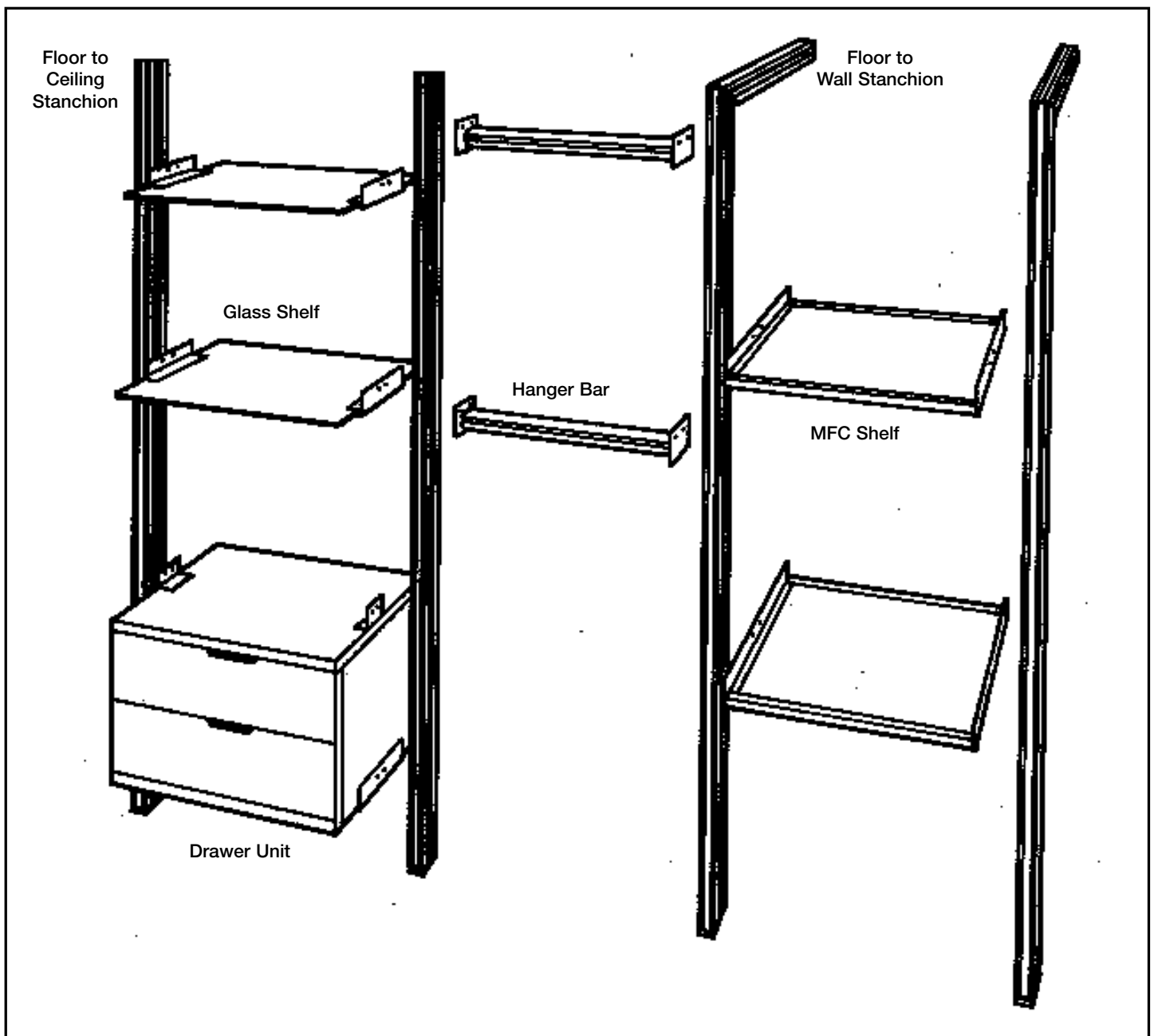
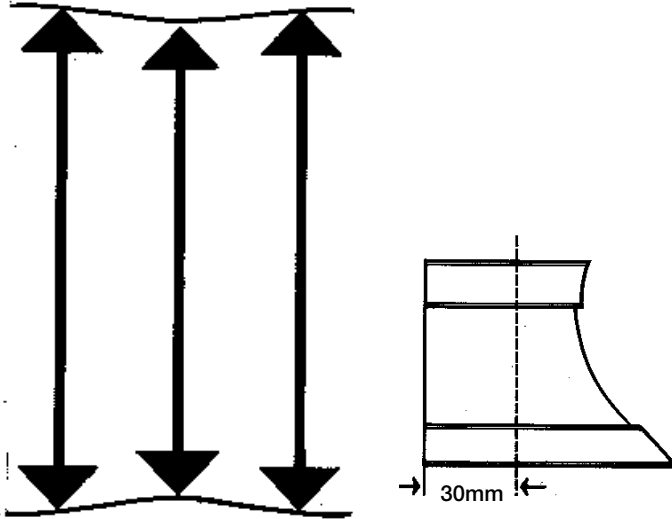

1

Floor to Ceiling Stanchions

Check the floor to ceiling height at each proposed stanchion position. If the difference is no greater than 5mm, use the minimum dimension. If greater, the stanchion will need to be cut to each individual measured size.

Each stanchion must be cut to the measured size minus 30mm (i.e. floor to ceiling dimensions 2440mm minus 30mm = 2410mm cut size)

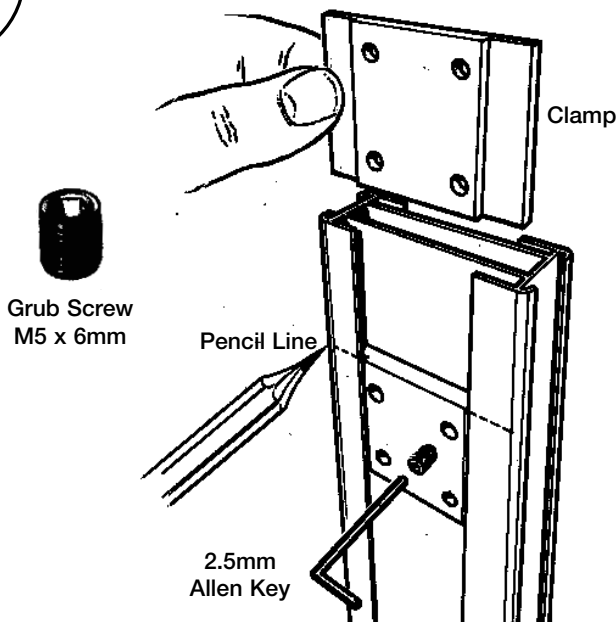
2

Next load one or both sides of the vertical stanchion with sufficient clamps to suit the number of shelves, hanger bars etc. (Note if you are using the drawer unit two clamps are required for the support bracket and the top retaining bracket).

NOTE: YOU CANNOT ADD FURTHER CLAMPS AFTER INSTALLATION.

Mark with a pencil on each stanchion the position you require each shelf etc. Fix clamps fairly accurately into position and using the M5 x 6mm grub screws using the 2.5mm allen key provided gently tighten into position. (Fine adjustment can be made later).

Make a final check that you have enough clamps on both sides of each stanchion.

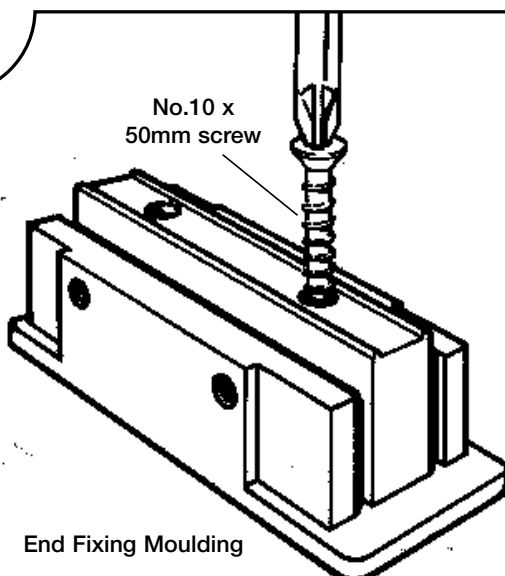
3

Next locate the grey nylon stanchion end fixing mouldings. Place moulding onto the floor at the required position. Drill a pilot hole to suit fixing required into timber or concrete floor structure through one of the centre holes and fix to the floor with a No.10 x 50mm screw and plug (if required).

Gently tighten screws ensuring moulding is in correct position and square then repeat procedure with other hole. Moulding should be firmly screwed into position **BUT DO NOT OVER TIGHTEN** as this may distort the moulding and prevent proper application of the stanchion.

Repeat procedure for each stanchion.

IMPORTANT: Care must be taken when drilling into the floor to avoid pipes and electrics.

4

Select the collar extension piece and slide this over the top end of each stanchion. Locate the stanchion onto the floor moulding. Do not secure at this stage. **MAKE SURE THE STANCHION IS PERFECTLY UPRIGHT IN BOTH DIRECTIONS.**

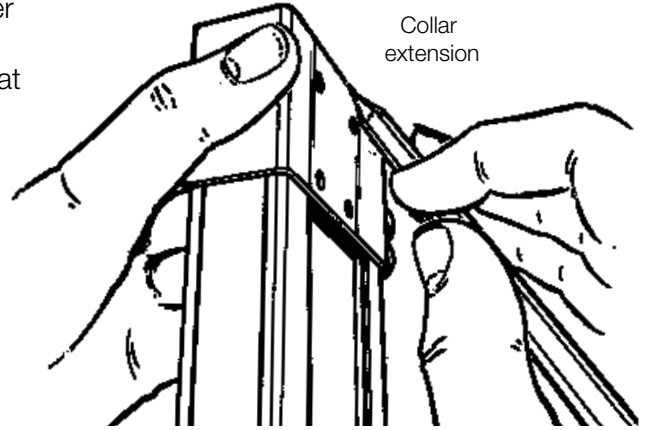
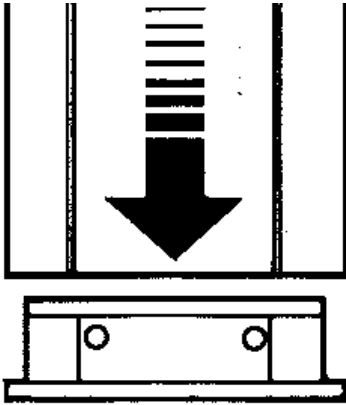

Slide the collar up to the ceiling and mark round the circumference of the collar against the ceiling with a sharp pencil. Repeat this for all stanchions. Remove stanchions from floor mouldings.

5

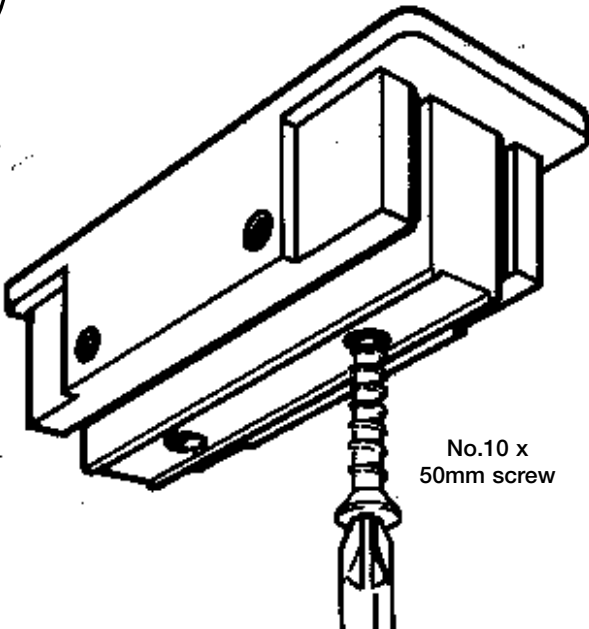

Take the other grey nylon stanchion end fixing moulding. Centralise within the scribed pencil line as done in stage 4 onto the ceiling.

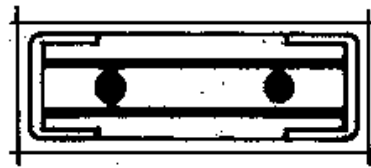

Fix to ceiling following similar procedures as floor using No.10 x 50mm screws. If fixing to plaster board a plaster plug must be used, not supplied.

IMPORTANT: Care must be taken when drilling into the floor to avoid pipes and electrics.

6

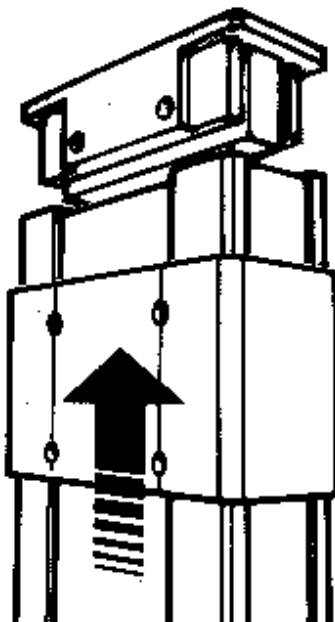

Place stanchion onto the floor moulding, line up under the ceiling moulding and slide the collar completely over the moulding so the collar touches the ceiling.

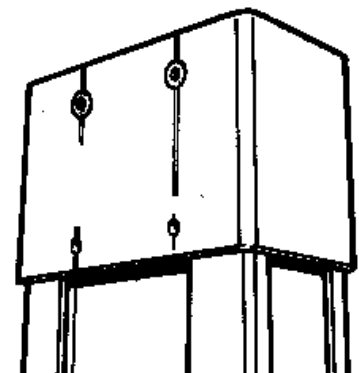

Counter Sunk Screw
M5 x 8



Locate the collar to the moulding with 2 M5 x 8mm counter sunk screws through the prepared holes into the tapped holes in the moulding.

7

Drill a 3mm pilot hole into the stanchion through the remaining 2 holes in the collar. Secure with self tapping screws.

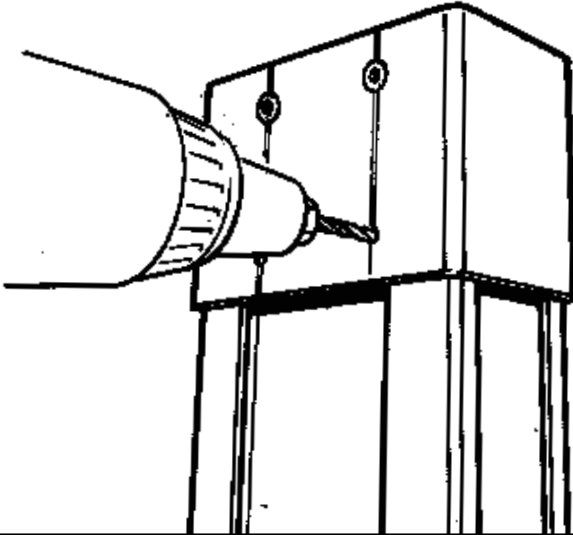

Self Tapping Screw
No.8 x 16mm

8

To finally secure each stanchion use the M5 x 6mm grub screws using the 2.5mm allen key provided into the 4 tapped holes in the floor moulding and tighten against the stanchion – **DO NOT OVER TIGHTEN.**

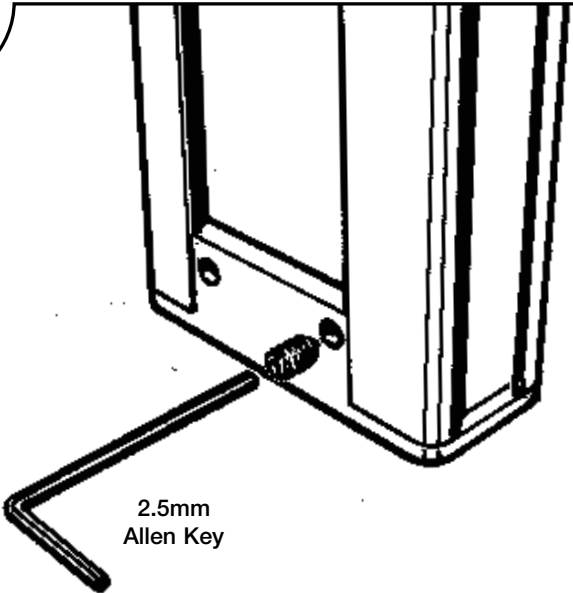

2.5mm
Allen Key



Grub Screw
M5 x 6mm

**FOR SHELF, RAIL AND DRAW UNIT FITTING
INSTRUCTIONS, SEE SECTIONS 14 TO 17**

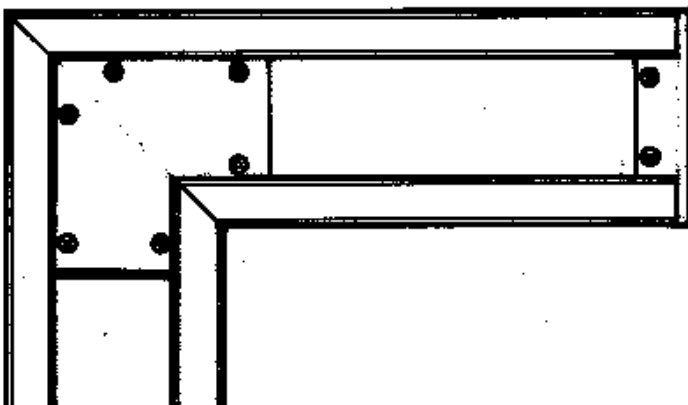

**90° Floor to
Wall
Stanchions**

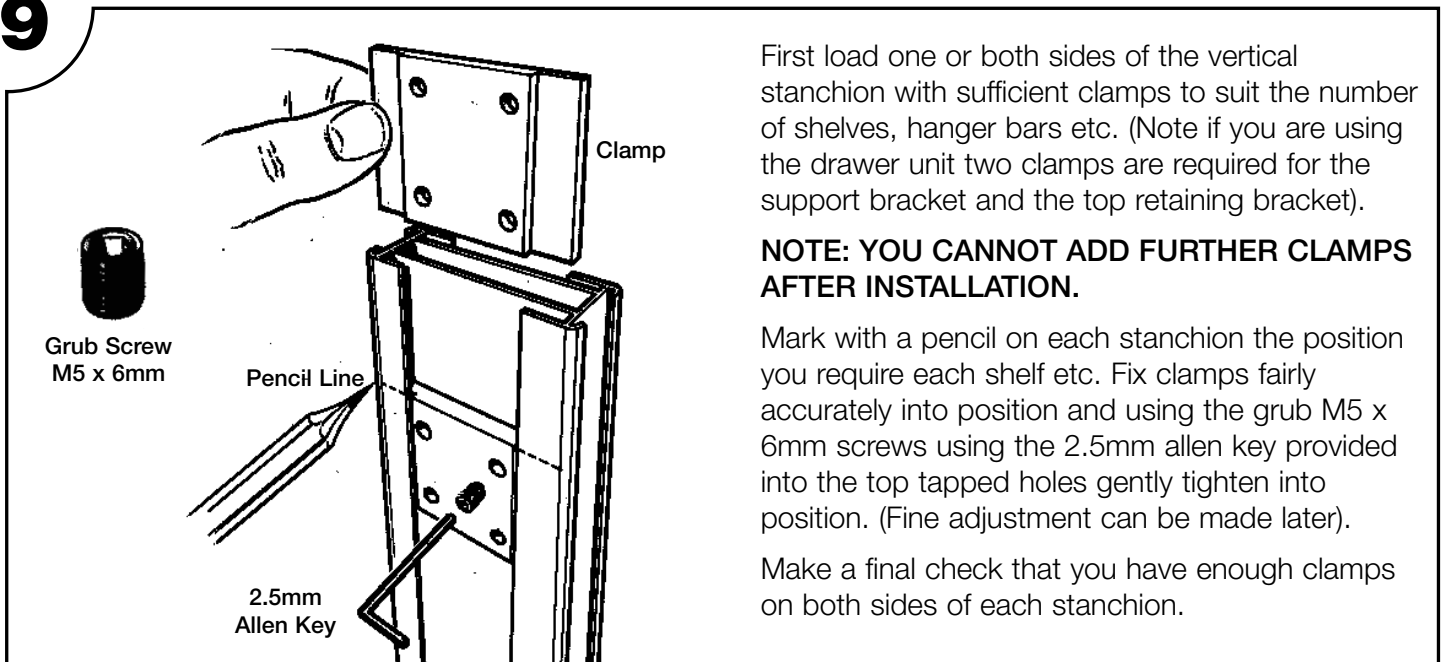
9

First load one or both sides of the vertical stanchion with sufficient clamps to suit the number of shelves, hanger bars etc. (Note if you are using the drawer unit two clamps are required for the support bracket and the top retaining bracket).

NOTE: YOU CANNOT ADD FURTHER CLAMPS AFTER INSTALLATION.

Mark with a pencil on each stanchion the position you require each shelf etc. Fix clamps fairly accurately into position and using the grub M5 x 6mm screws using the 2.5mm allen key provided into the top tapped holes gently tighten into position. (Fine adjustment can be made later).

Make a final check that you have enough clamps on both sides of each stanchion.

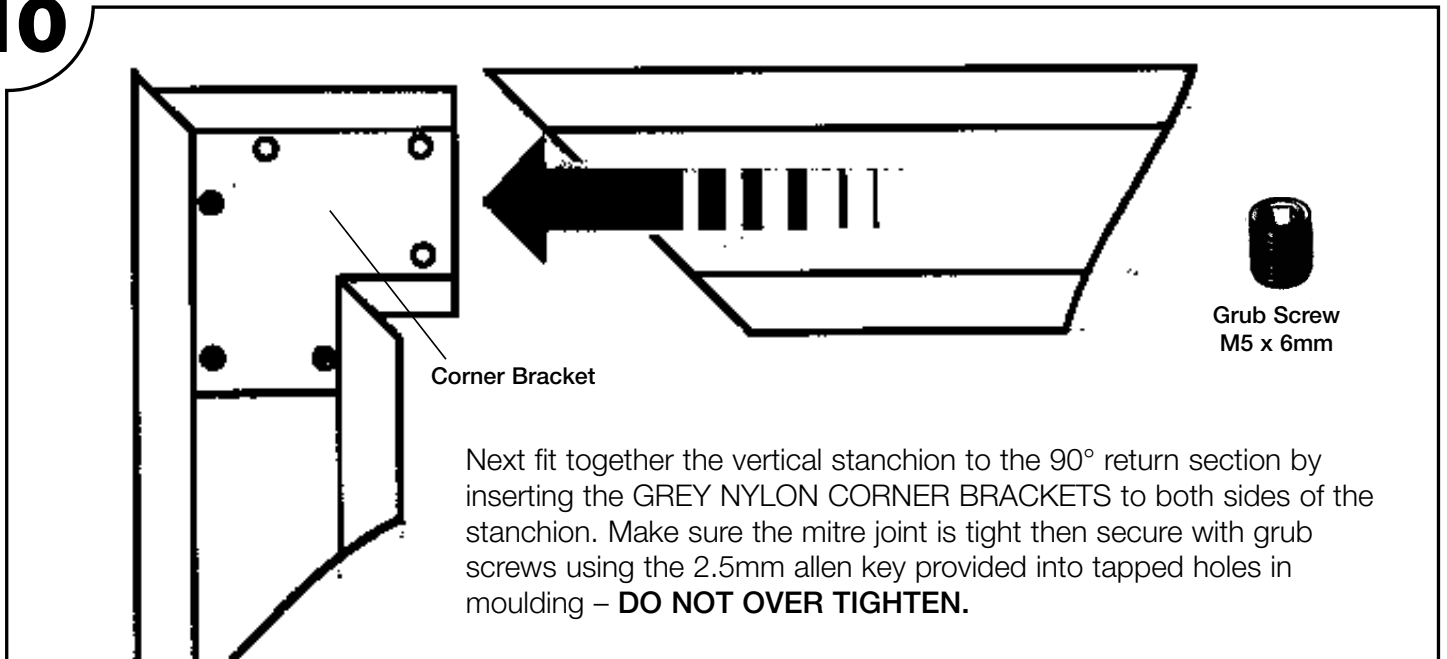
10

Next fit together the vertical stanchion to the 90° return section by inserting the GREY NYLON CORNER BRACKETS to both sides of the stanchion. Make sure the mitre joint is tight then secure with grub screws using the 2.5mm allen key provided into tapped holes in moulding – **DO NOT OVER TIGHTEN.**

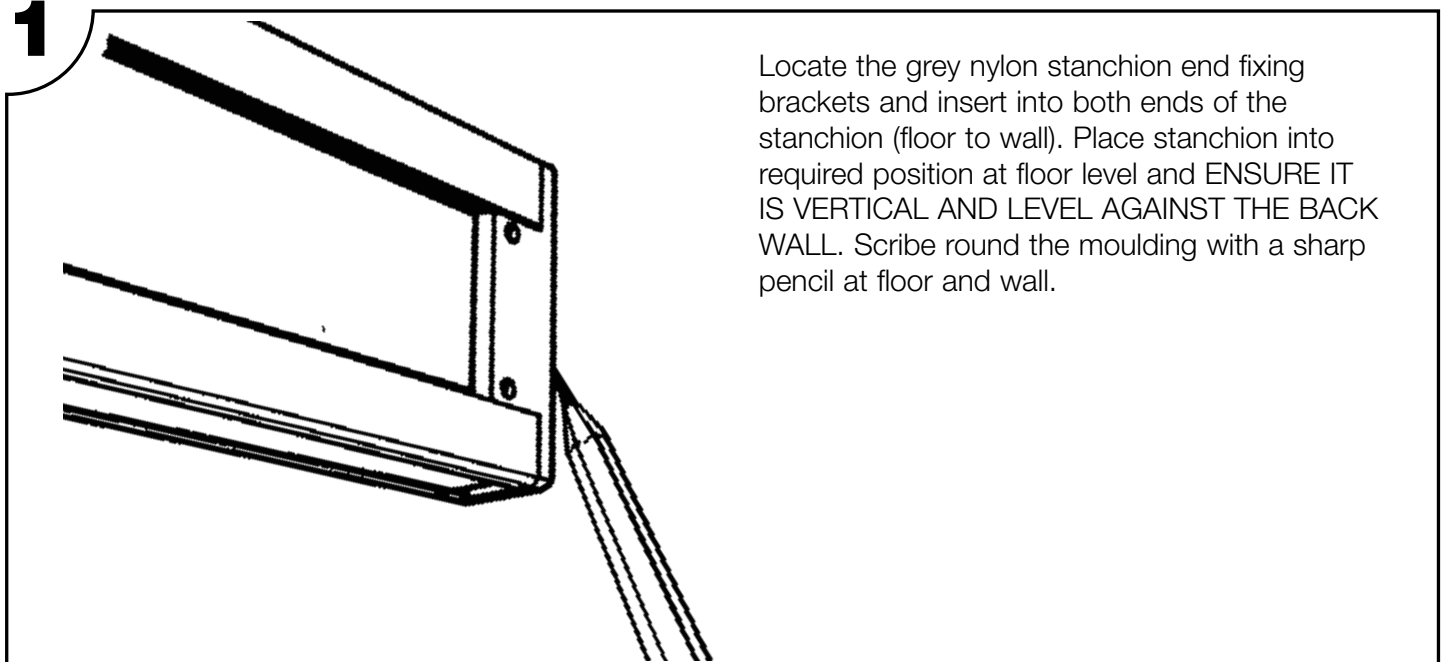
11

Locate the grey nylon stanchion end fixing brackets and insert into both ends of the stanchion (floor to wall). Place stanchion into required position at floor level and **ENSURE IT IS VERTICAL AND LEVEL AGAINST THE BACK WALL.** Scribe round the moulding with a sharp pencil at floor and wall.

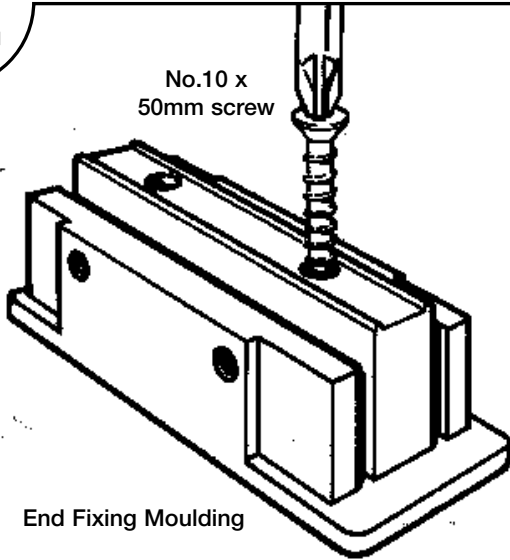
12

Remove grey nylon stanchion end fixing moulding and place over pencil outline at floor and wall. Drill a pilot hole to suit fixing required into plaster(board) or brickwork structure. Fix through centre two holes with No.10 x 50mm screw and plug (if required).

Gently tighten screws ensuring moulding is in correct position and square then repeat procedure with other hole. Moulding should be firmly screwed into position BUT DO NOT OVER TIGHTEN as this may distort the moulding and prevent proper application of the stanchion.

Repeat procedure for each section.

IMPORTANT: Care must be taken when drilling into the floor to avoid pipes and electrics.

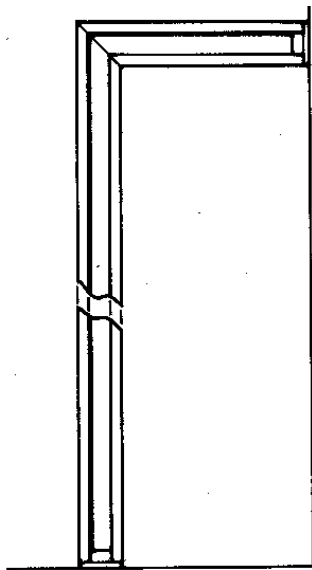
13

Replace stanchion over floor moulding and then locate over wall moulding. Use grub screws into tapped holes using 2.5mm allen key in mouldings to secure stanchion at the floor and wall – DO NOT OVER TIGHTEN.



Grub Screw
M5 x 6mm

14

Glass Shelves

These are supplied in two widths to suit either a 600mm or 900mm stanchion centres.

Select the glass shelf bracket, secure to each side of the stanchion with counter sunk screws into bottom two tapped holes in the clamp. With care select the appropriate glass shelf and slide into the channel part of the retaining bracket, making sure the shelf is square and centred. Then insert 200mm length of the clear flexible gasket with the flat edge against the glass into the gap between the top face of the shelf and bracket – push fully to lock the shelf in position. Repeat for each shelf bracket.

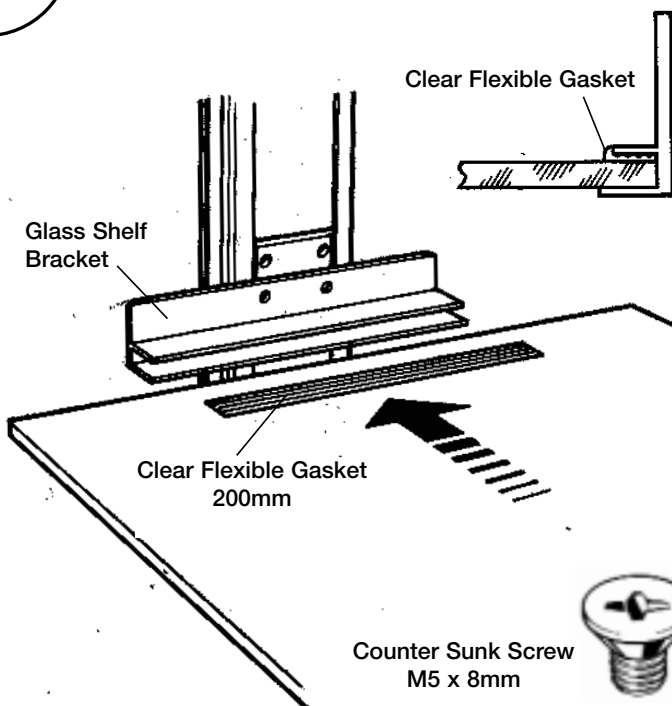

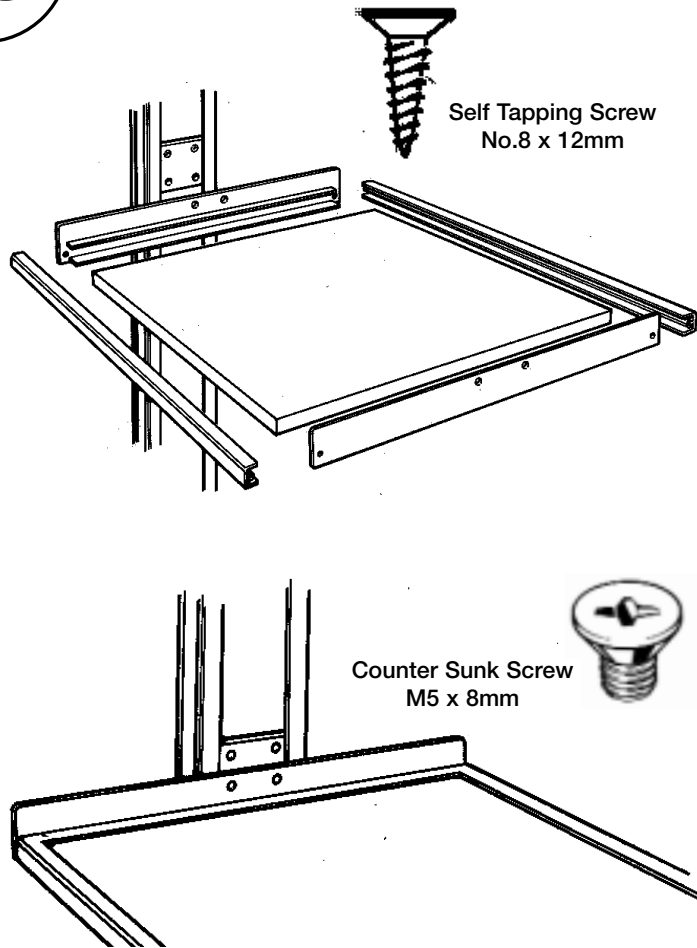
15

MFC Shelves

These are supplied as 600mm and 1200mm kits comprising 18mm thick MFC board 2 x aluminium brackets and 2 x aluminium edge trims together with 4 self tapping screws.

If you have set your stanchions at 600mm or 1200mm centres then the shelf can be assembled without any further preparation.

If your stanchion centres are less than 600mm or 1200mm it is a simple matter of cutting down the length of the MFC board and aluminium edge trims to fit.

To assemble the shelf, knock on the end brackets to the MFC shelf with the MFC in a central position. Push in both edge trims with the rounded corner uppermost and secure with No.8 x 12mm self tapping screws into the edge trim profile. The shelf can now be secured to the stanchion with M5 x 8mm counter sunk screws into the bottom two tapped holes in the clamp. (see illustration)

Repeat for each shelf bracket.

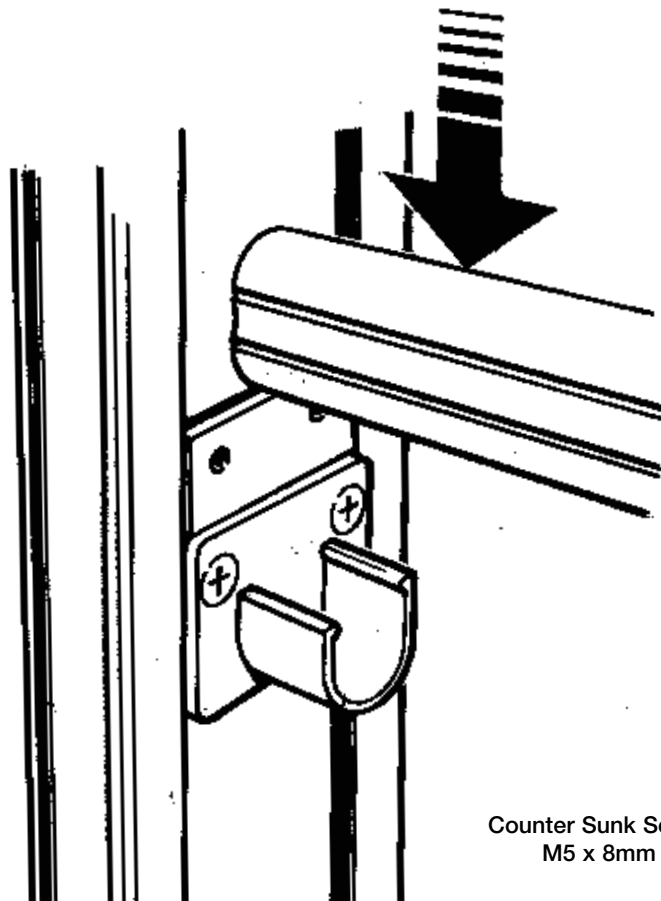
16

Hanger Bars

These are supplied as 600mm & 1200mm kits comprising 2 x moulding fixing brackets of 1 x aluminium hanger rail.

If you have set your stanchions at 600mm or 1200mm centres then the hanger bracket can be assembled without any further preparation.

If your stanchion centres are less than 600mm or 1200mm it is a simple matter of cutting down the length of the hanger rail to fit. First attach the two end mouldings to both stanchions using M5 x 8mm counter sunk screws into bottom two tapped holes in the clamp. An accurate measure can now be taken of the hanger rail.

Snap the hanger rail into both mouldings as illustration.

Repeat for each hanger rail clamp.

17

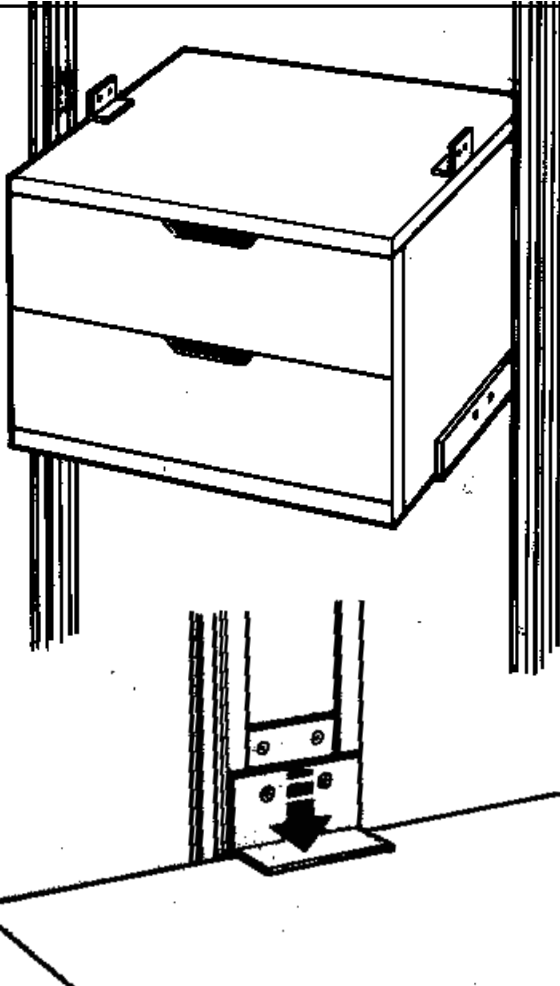

Two Tier Drawer Unit

This is supplied as a self assembly unit – assembly instructions provided with the product.

The stanchions must be set at 600mm centres to accommodate the drawer unit. Select the support brackets and secure to the stanchions with M5 x 8mm counter sunk screws into the bottom two tapped holes in the clamp. Place onto the bracket the drawer unit centrally in width and depth.

Next select the small 75mm wide bracket and secure to the clamp at the top of the drawers with M5 x 8mm counter sunk screws. Adjust top screws in the clamp to centre the bracket making sure it is tight against the drawer top.

Repeat for each drawer bracket.

Counter Sunk Screw
M5 x 8mm



FINAL ADJUSTMENTS

Final adjustment – using a spirit level ensure that all shelves, hanger bars, drawer units etc are level making any adjustments by slackening off the grub screws and retightening in correct location. Check all location screws are properly tight but please **REMEMBER DO NOT ASSERT EXTREME PRESSURE A PINCH FIT IS QUITE SATISFACTORY.**

Do not use abrasive solution to clean the finished assembly, any grease marks should be cleared with white spirit and often treated as a normal piece of furniture.



Pushing back the boundaries of space

PORTICO Midlands Limited, Middlemore Lane, Aldridge, Walsall, West Midlands WS9 8SP
T: 01922 743211 - F: 01922 743513 - E: sales@porticomidlands.co.uk

www.spaceslide.co.uk