

Installation Instructions

MERCURY GLASS DOOR

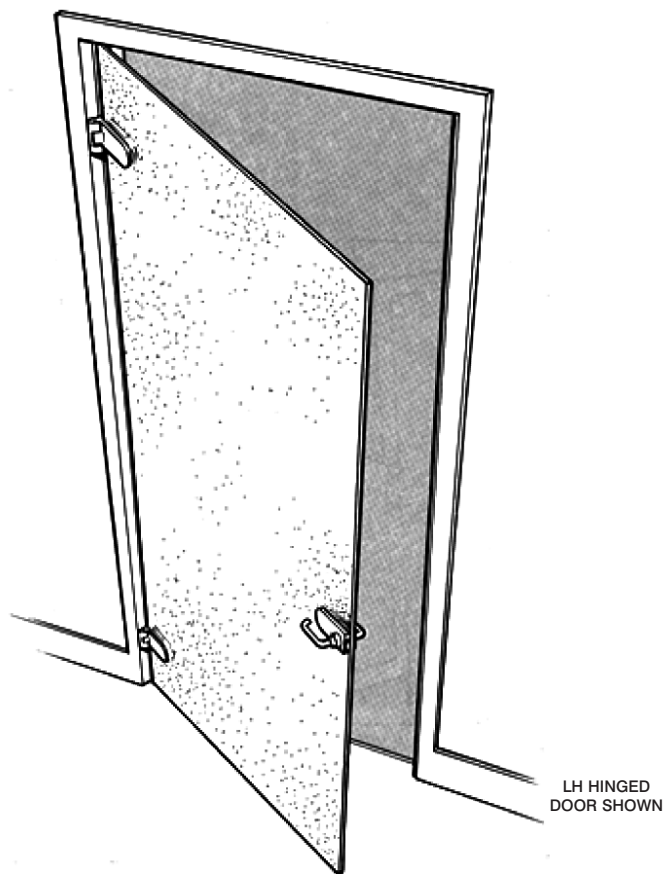

spaceslide®

TOOLS REQUIRED

- 2 x Hinges with Allen Key & Fixings.
- 1 x Latch Set with Allen Key (Please

NOTE: The latch is adjustable for use with a left hand or a right hand hinged door. Check that the latch handing suits

your needs before fitting it and adjust it if necessary - see Latch Handing Checking & adjustment).

- 1 x Glass Door Panel.
- 1 x Set of Instructions.

NOTE: HINGE/LATCH/HANDLES MAY VARY FROM THOSE SHOWN.

LATCH SET

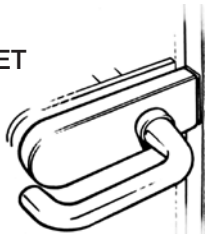

HINGE



1

PREPARING THE DOOR

TAKE CARE NOT TO SCRATCH ANY PARTS. Take off all of the packaging and check the door size and its type (Etched or clear). When satisfied lay the glass panel onto a flat surface, (covered with suitable protection) to fit the hinges.

2

FIXING THE HINGES

PLEASE NOTE: If your glass panel is etched, it is usual practice to face the etched side away from the door frame

Strip down the hinges by removing the screws with the Allen key provided. Position through the holes in the glass panel making sure that the washers and Plastic sleeves are fitted - see diagram then tighten the screws.

Make sure that there is a gap between the hinge and the edge of the glass panel when the hinge is in its closed position - see diagram.

Now fit the other hinge in the same way.

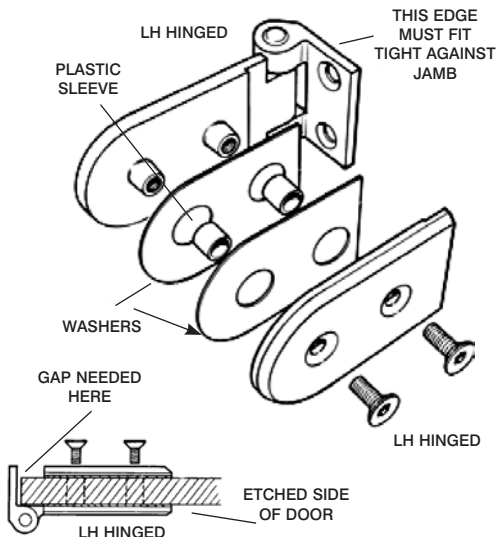

3

FITTING THE DOOR INTO THE FRAME

PLEASE NOTE: If replacing an existing door you will need to fill and paint the existing hinge recesses and screw holes with resin wood filler, as they are no longer required.

For the next stage, two people may be needed.

You can choose to install the glass door with the hinges fixed on its left hand or right hand side (Viewed with door opening towards you). When deciding take care that it will not contact radiators or any sharp objects when opening, or cover a light switch when open.

Start by placing suitable packing under the door so that the gap between the door and the frame is the same around both sides and top when closed. If the frame is not square or its top is not level, you should raise the door as much as possible but ensure that the top edge of the glass panel does not catch the frame when closing - see diagram.

When satisfied with the door position mark the position of the top and bottom edge of the two hinges onto the frame - see diagram.

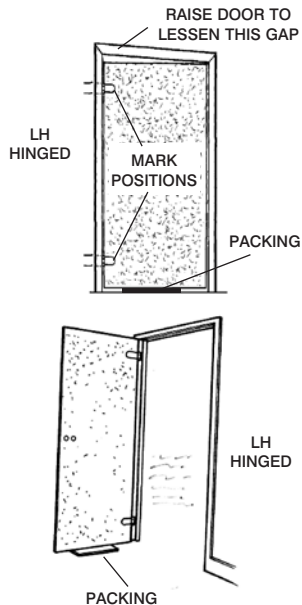

4

DISMANTLING THE LATCH

Unscrew the two black plastic collars and remove the covers.

Remove the two fixing screws, using the Allen key provided, and part the inner sections.

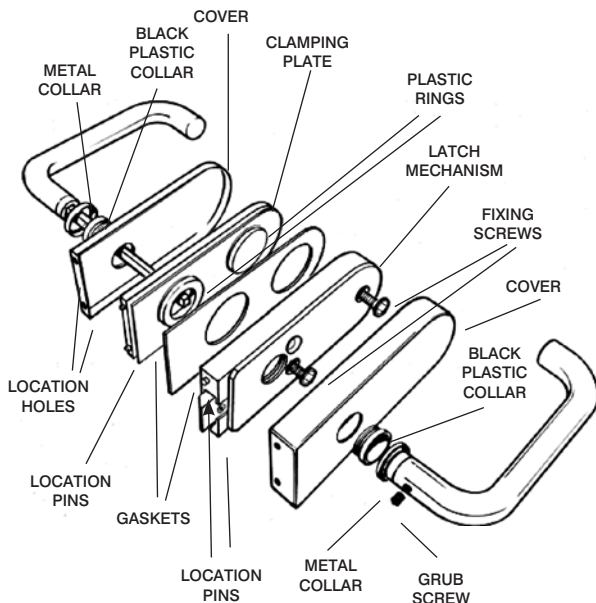

5

LATCH HANDING - CHECKING AND ADJUSTMENT

To check the current handing sit the latch Mechanism on its side, ensuring that the flat side of the latch bolt is uppermost, then carefully prise off the plate if still fitted, and read the handing mark that is located where shown. You will see either 'L' for Left Hand or 'R' for Right Hand.

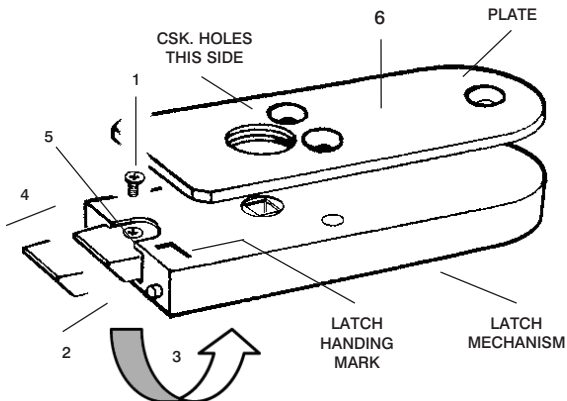

Handing can be changed as follows:

1. Remove the latch bolt Screw with a screwdriver.
2. Withdraw the Latch bolt from the Latch Mechanism and put it to one side.
3. Turn the Latch mechanism over so that the latch handing mark you need is uppermost.
4. Re-fit the latch bolt with its flat side uppermost.
5. Re-fit the Latch bolt Screw and tighten it fully.
6. Re-fit the plate to the top of the latch mechanism with its countersunk holes uppermost.

6

FITTING THE LATCH TO THE DOOR

Fit 1 gasket and 2 plastic rings to the clamping plate then locate its bosses into the holes of the glass panel from the side facing the door frame. Now, fit 1 gasket, then the Latch Mechanism, to the side of the door facing away from the door frame, align the holes in the two parts, fit the two fixing screws and tighten them fully.

FITTING THE COVERS

Fit the two covers by first engaging them over the location pins, then secure by screwing the black plastic collars into place - see step 4.

FITTING THE HANDLES

Select the handle with the square spindle, slide on its metal collar and then push it through the latch set. When fully through, push on the other handle and its metal collar and tighten them together with the 3mm grub screw in the handle side - see step 4.

7

FITTING THE STRIKER PLATE & DOOR SEAL

Close the door and mark the striker plate position. Remove and chisel out the centre hole to the correct depth. Fit the plate, drill two pilot holes and fix with the two screws provided - see diagram.

Check that the glass panel does not catch the striker plate when closing.

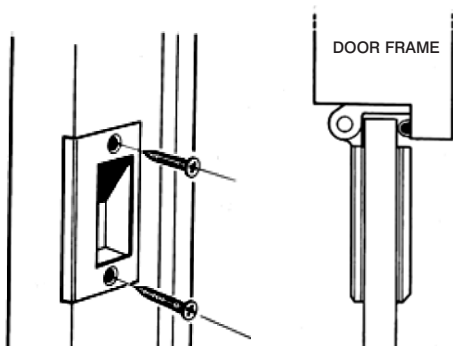

**DO NOT USE ABRASIVE OR CHEMICAL BASED CLEANING AGENTS
OR FILLERS ON THE FRAMES OF YOUR SPACESLIDE PRODUCTS;
IT MAY RESULT IN TARNISHING OR PEELING.**

spaceslide®

Spaceslide Showrooms

Northgate, **Aldridge**, Walsall, West Midlands WS9 8TH

T: 01922 743211 E: sales@spaceslide.co.uk

Unit 15, McDonald Way, Hemel Hempstead Ind Est, **Hemel Hempstead** HP2 7EB

T: 01442 239900 E: info@britanniawardrobes.co.uk

www.spaceslide.co.uk