

Installation Instructions

Free Standing Wardrobes

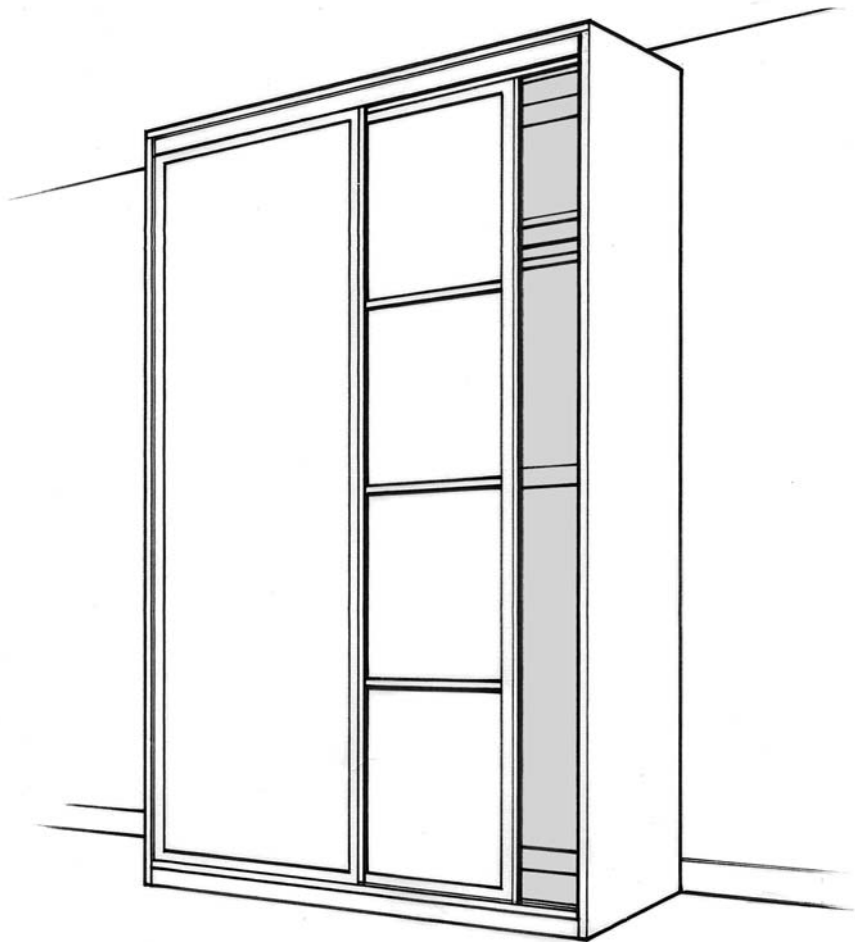

PREPARATION

You will need two people in the assembly of your wardrobe.

Make sure you have enough flat area to assemble the wardrobe, close to the area the unit is to fit.

Familiarise yourself with the panels, bracing strips and position of cams which must be hidden from view. Follow diagrams for guidance.

Take care not to twist, knock or scratch the panels. Excessive movement, will loosen construction.

Make sure cams and dowels are in the correct holes, check the diagrams.

Always check that the arrow on the cams aligns with the metal dowel (see diagram).

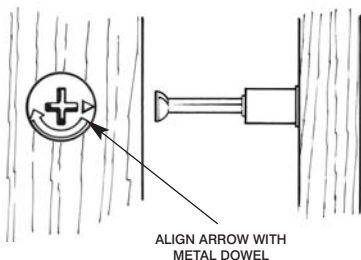

Align cams and dowels carefully before pressing the panels together.

Tools Required:

2mm Diameter Drill for fitting back panels.

Screwdriver to fit screws and cams.

Rubber Hammer (Optional).



CAM SCREWS



METAL DOWEL

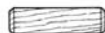

DOWEL

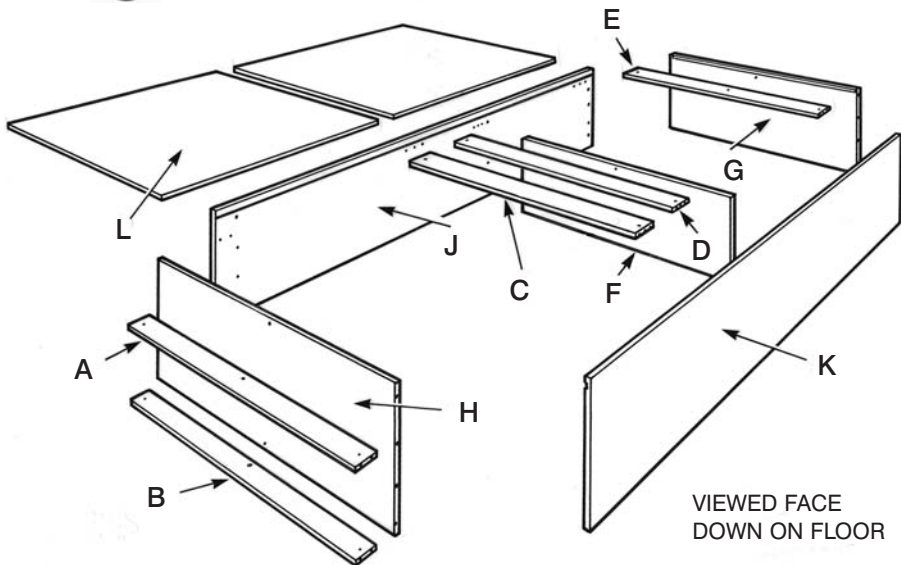

1

PREPARING THE PANELS

IMPORTANT: Make sure surface of floor is free from any particals which may scratch the surface.

○ DOWELS ● METAL DOWEL

⊕ CAM SCREWS

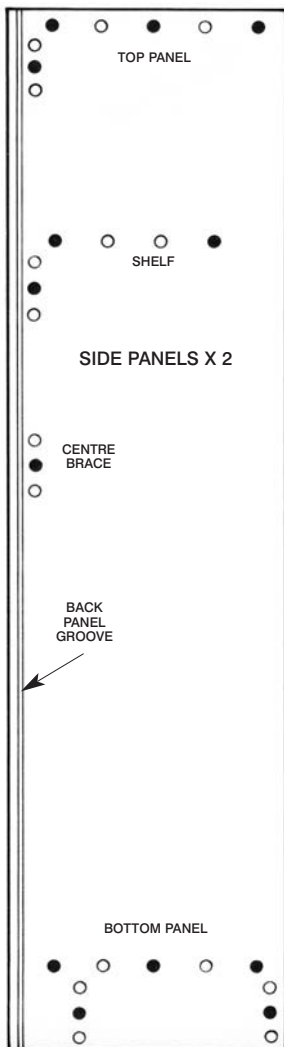

Position all can screws wood dowels and metal dowels (see diagram).

TOP PANEL BRACING STRIP
VIEWED FROM REAR



SHELF BRACING STRIP
VIEWED FROM REAR

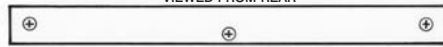

MID BRACING STRIP
VIEWED FROM REAR

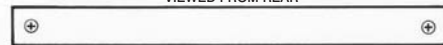

BOTTOM PANEL BRACING STRIP/PLINTH
VIEWED FROM REAR

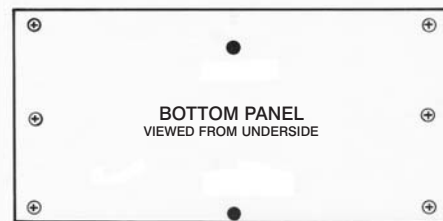

BOTTOM PANEL BRACING STRIP
VIEWED FROM REAR



2

FITTING BRACING STRIPS TO THE TOP PANEL, SHELF AND BOTTOM PANEL

Bracing strips must be fitted to the panels and shelf before they are fitted to the side panels.

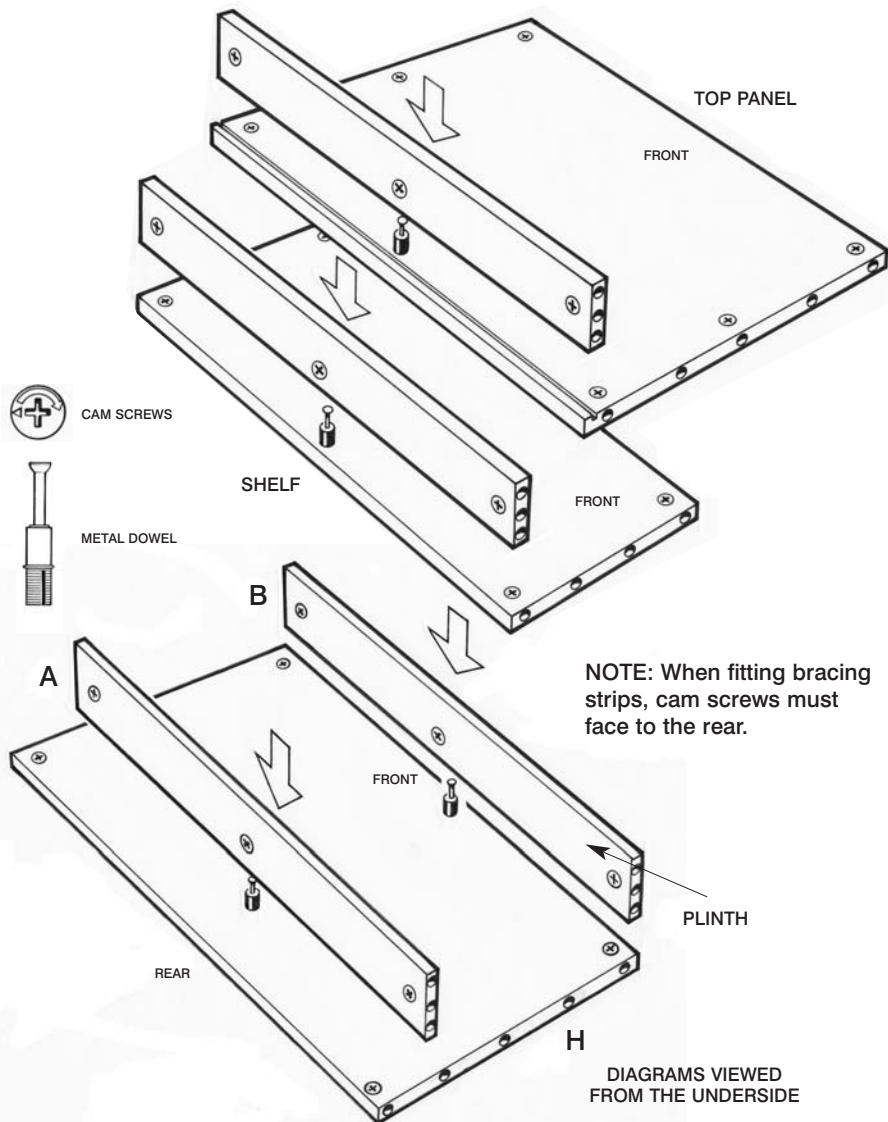

3**FITTING BOTTOM PANEL TO THE SIDE**

Carefully lift the bottom panel H onto the cams and dowels.

When pressed together fully tighten the cam screws.

Make sure panels sit together before tightening cam screws.

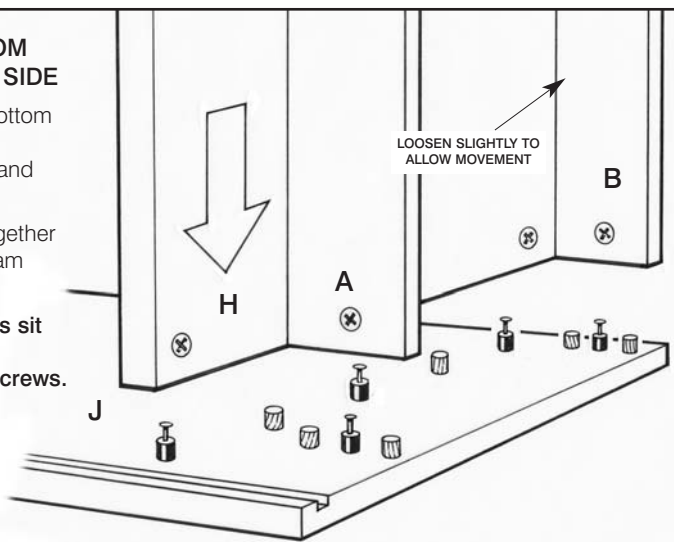
**4****FITTING TOP PANEL AND SHELF TO SIDE**

Position top panel G and bracing strip E onto the the dowels, press together, and fully tighten the cam screws.

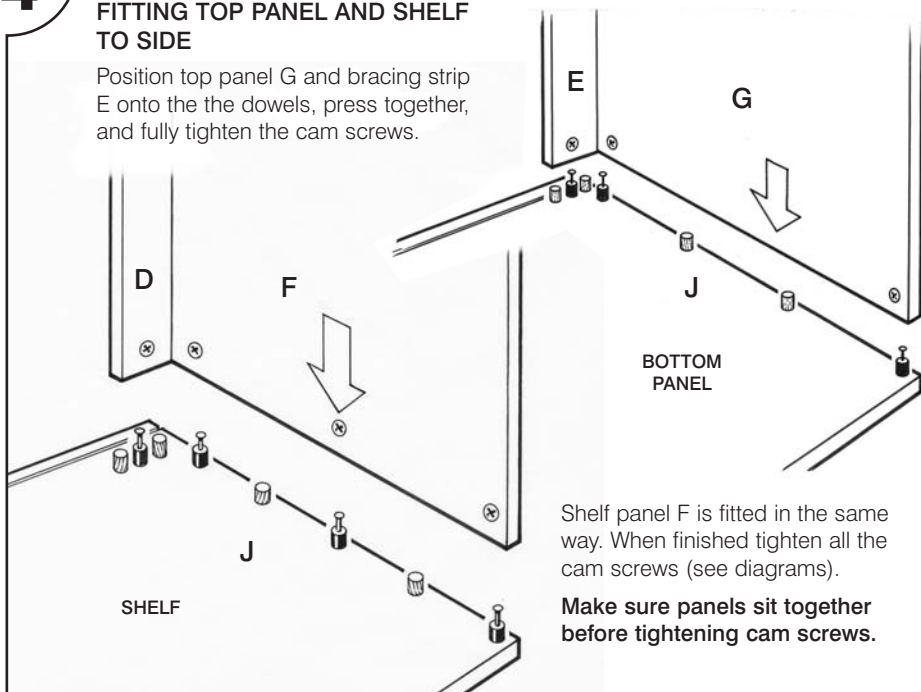

Shelf panel F is fitted in the same way. When finished tighten all the cam screws (see diagrams).

Make sure panels sit together before tightening cam screws.

5

FITTING THE CENTRE BRACING STRIP ONTO SIDE PANELS

Carefully position bracing strip C onto the dowels, press together and tighten cam screws.

IMPORTANT: Cams must face to the rear (see diagram).

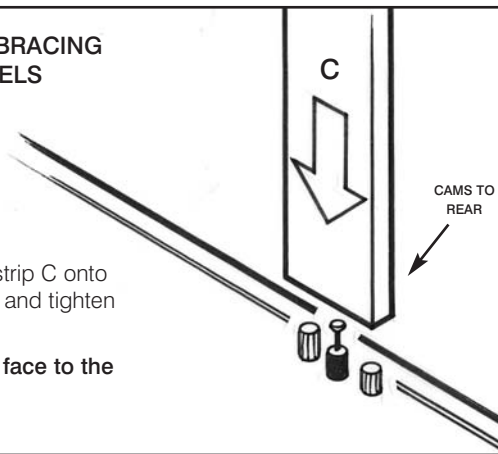
**6**

FITTING THE OTHER SIDE PANEL

With a person at each end, carefully lift the side panel onto the dowels, we recommend you start at the bottom and work up the wardrobe positioning the metal dowels and wood dowels as you proceed.

When all the holes are aligned, tap together with the palm of your hand.

Tighten all the cam screws fully.

It is advisable to now check every cam screw before you move the wardrobe.

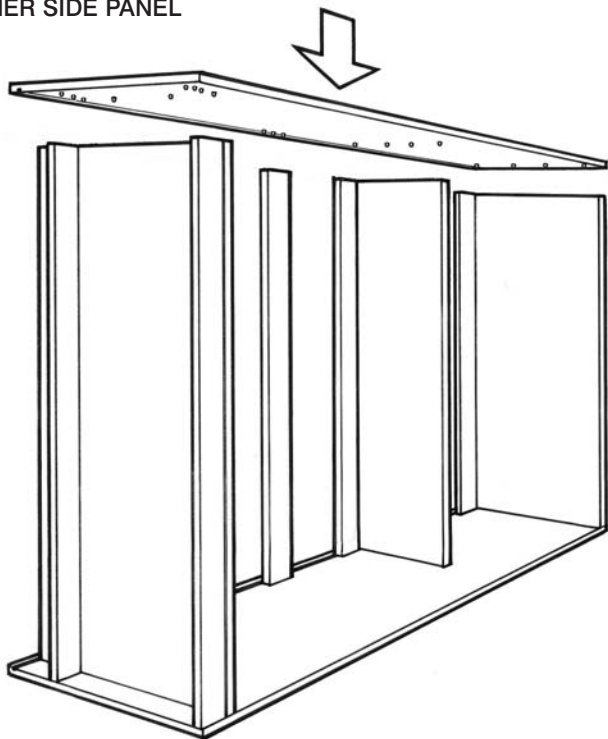

7

FITTING THE BACK PANELS

Carefully turn the wardrobe onto its front face. If space is limited, this section can be achieved with the wardrobe on its side.

Slide the top back panel, smooth/white side to the inside of the wardrobe until it fits into the groove on the top panel G (see diagram).

Now follow the same procedure with the bottom panel.

With the panels tight together, measure across the corners to check for squareness (see diagram) **it is important the unit is square to enable the sliding doors to fit correctly.**

If measurement out, move the wardrobe a little to correct.

Now secure the back panels with 15mm screws provided at 250mm spacing drill a pilot hole first through the back panel into the bracing strips A, C and E **just enough to break through the hard surface (1mm).**

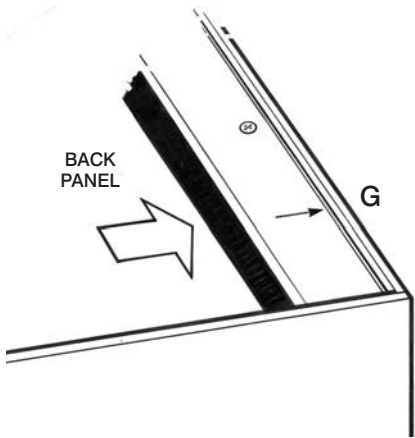

Take care not to pierce to inside face of the bracing strip.

Carefully move wardrobe into its upright position into the area it is to fit.

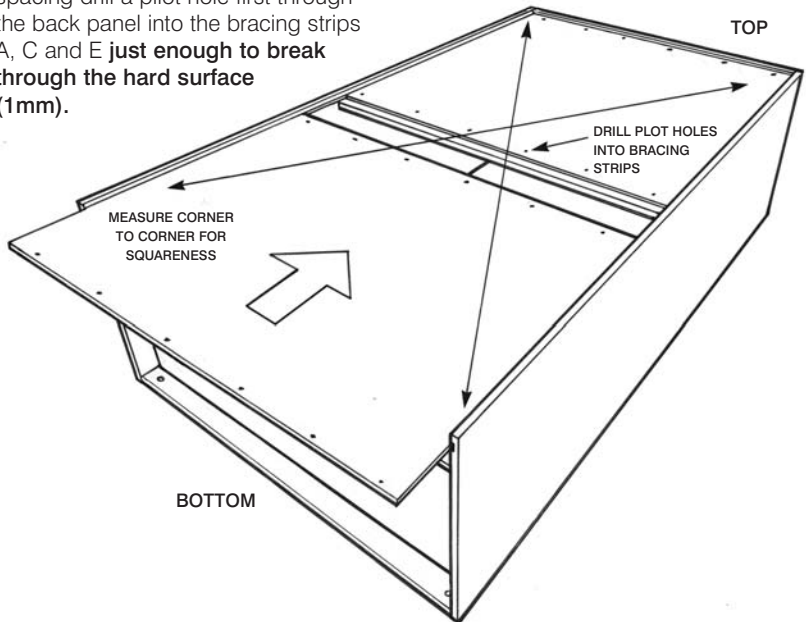

8

FITTING TOP AND BOTTOM DOOR TRACKS

Installing the top track

Position the top track 2mm back from the front face of wardrobe (see diagram).

Through the pre drilled hole in the top track drill a small pilot hole **3mm deep** into the top panel.

Fix with 15mm screws provided (see diagram).

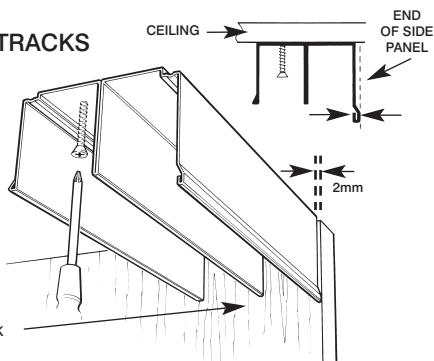

Installing the bottom track

Position the track as diagram 15mm back from the front face of the wardrobe through the pre drilled holes in the track drill a small **3mm deep** pilot hole into the bottom panel.

Fix with 15mm screws provided. **Do not overtighten.**

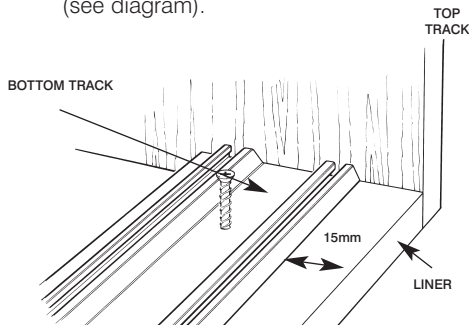

9

FITTING THE HANGING RAIL

Fix the two rail holders into the pre-drilled holes in the side of the wardrobe using 15mm screws provided.

Slide the centre support onto the rail. Connect the rail into either rail holder.

Move the centre support up against the holder, then insert the rail into the holder on the other side.

Fix the centre support into the two pre-drilled holes with 15mm screws provided (see diagrams).

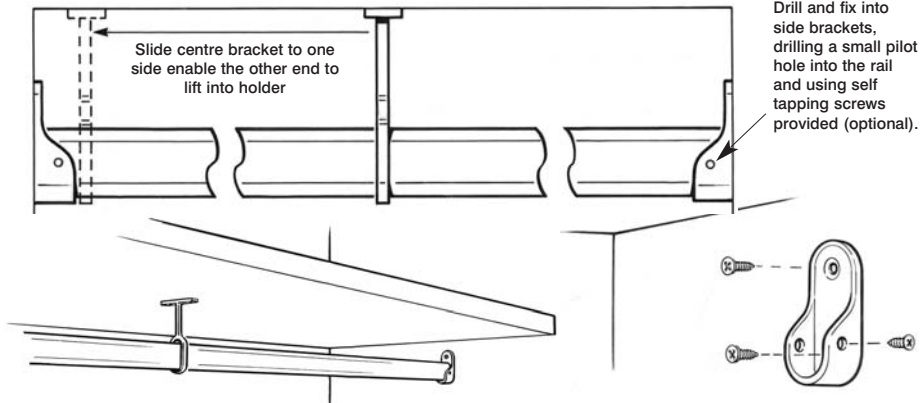

INSTALLING THE DOORS

Tilt the door as shown and insert the top guides into the rear channel. Insert the bottom rollers into the rear groove of the bottom track. Take care not to scratch the bottom track. Repeat with the second door using front channel and groove.



POSITION THE FIRST
DOOR ONTO THE
INSIDE RUNNERS

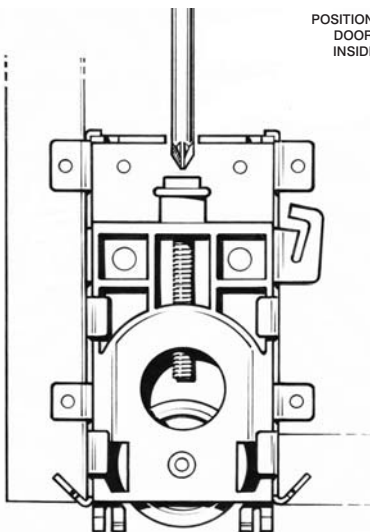

ADJUST DOORS

For vertical adjustment of each door use a pozi-drive screwdriver on the bottom rollers (see diagram). Once happy with the final adjustments.



Pushing back the boundaries of space

Spaceslide Showrooms

Northgate, **Aldridge**, Walsall, West Midlands WS9 8TH

T: 01922 743211 - F: 01922 743513 - E: sales@spaceslide.co.uk

Drew House, Ebbens Road, Apsley, **Hemel Hempstead**, Hertfordshire HP3 9QS

Retail: 01442 239900 - Trade: 01442 269963 / 252299 - F: 01442 244121 E: sales@spaceslide.co.uk

www.spaceslide.co.uk